

**12 VOLT**  
**SOLAR CONTROLLER**  
**4 STAGE CHARGING**



## **WARNINGS – IMPORTANT PLEASE READ**

- SC110 is designed for indoor use only
- Use SC008 or SC015 for outdoor applications
- Do not disassemble the controller. Take to a qualified person if the unit requires repairing.
- Lead acid batteries can be dangerous. Ensure no sparks or flames are present when working near batteries
- Eye protection should always be used. Never short circuit the battery
- Given sufficient light solar panels always generate energy even when they are disconnected.
- Accidental 'shorting' of the terminals or wiring can result in sparks causing personal injury or a fire hazard. We recommend that you cover up the panel(s) with some sort of soft cloth so you can block all incoming light during the installation. This will ensure that no damage is caused to the Solar Panel or Battery if the wires are accidentally short circuited
- Always install a battery fuse on each circuit including the solar controller

## **MOUNTING THE DEVICE**

### **The Solar Controller is mounted as below**

The quickest and easiest way to mount the unit is to use the two plastic spacers and self tapping screws supplied and mount the unit to a flat surface.

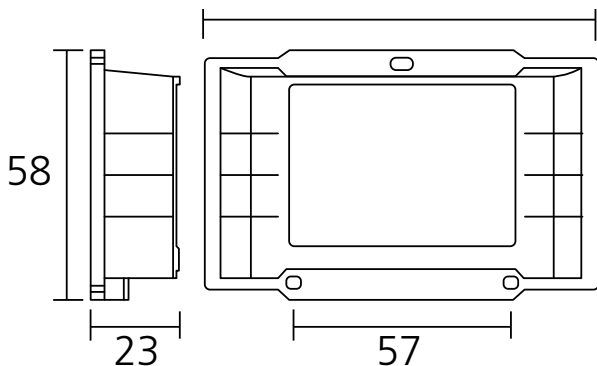

Fig 1.

## FEATURES

- 4 Stage charging ensures the battery is charged to the optimum level
- Advanced MCU control pulse width modulated (PWM) technology, high efficiency operation
- Programmable for Gel, AGM, Conventional lead-acid (WET) and Calcium Batteries
- Built in regulator to prevent your battery from being overcharged. Overcharging occurs when the charge voltage is unregulated. This can result in premature battery failure
- In built regulator prevents your battery from being under charged, in the solar energy field, battery undercharge often occurs, especially on some conventional Lead Acid or Calcium batteries; the unit provides an automatic equalization feature for deeply drained conventional Lead Acid battery or Calcium battery, as well as provides a cycling automatic equalizing feature every 28 days
- These solar controllers can be connected to the battery permanently to keep the battery fully charged by using a process called "floating". This means the controller will stop charging when the battery is full and will automatically start charging the battery as required. This process will also reduce water loss and help prevent the battery from 'drying out'
- Protects your battery from discharge at night. Under low light or no light conditions the solar panel voltage could be less than the battery voltage. The unit contains a special circuit which prevents current flowing back from the battery and into the solar panel
- Colored LED's to easily indicate the operational status and battery conditions
- Digital LCD to directly display battery voltage, charging current, charging capacity (Amp hour), battery types, full charge and faulty codes
- Provides external battery temperature sensor (Optional)
- Multi charging protections against reverse polarity, short circuit, over temperature, over voltage, etc.
- Surface Mount or Flush Panel Mount options
- Conformal-coating circuit boards and plated terminals protect the unit in hostile environments

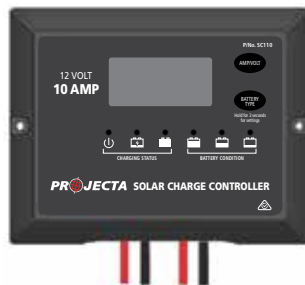

Fig 2.

**For use with 12Volt Solar Panel Only. Suitable for solar panels up to 120 Watts (SC110).**

## WIRING CONNECTIONS

To protect the battery and solar panel, it is recommended that you place an inline fuse on the positive wire of both the 'Solar' and 'Battery' circuits. A 20A fuse is required and should be installed as close to the battery/solar panel as possible.

The Solar Controller has 4 terminals which are clearly marked 'Solar' and 'Battery'.

There is a (12V) and earth (GND) terminal for each circuit.

Refer to the wiring diagram below.

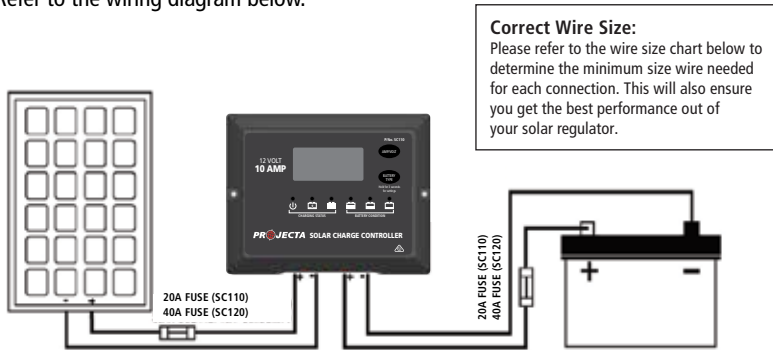

Fig 3.

	P/No	Battery Connection	Solar Array Connection		
Length of Wire		< 1m	6m	9m	12m
Size (mm <sup>2</sup> )	SC110	1.3	1.3	2.1	3.3

1. Using the string wires, tightly screw the wires to the "Solar" terminal on the back of the controller and connect to the solar panel as shown above in Fig 3.
2. Using the string wires, tightly screw the wires to the "Battery" terminal on the back of the controller and connect to the battery as shown above in Fig 3.

When the connections are completed, the Solar Controller will start working automatically.

## OPERATION – LCD DISPLAY

Please check your battery manufacturer's specifications to select correct battery type. The unit provides 4 battery types for selections: Gel, AGM, WET (conventional lead acid), and Calcium.



Fig 4.

Press **BATTERY TYPE** button and hold for 3 seconds to go into your battery type selection mode, the battery type you select will be shown on the LCD meter, the default setting is AGM Battery; the controller will automatically memorize your battery type setting.

**Caution: Incorrect battery type setting may damage your battery.**

When the controller powers on, the unit will run 'self-qualify' mode and automatically show below items on LCD before going into charging process.

888 Self-test starts, digital meter segments test

8.8.8 Software version test

8.2.8 v 89.0 A Rated voltage and current test

After going into the charging process, the LCD displays the charging status as below:  
Press **VOLT/AMP** button in sequence, the LCD will display in turn with Battery Voltage, Charging Current and Charged capacity (Amp-hour).

**Display in the day time:**

8.2.8 v ⇒ 89.0 A ⇒ 8.2.0 Ah

**Display during the night:**

8.2.8 v ⇒ Ah

**Display when the battery is fully charged**

Press **VOLT / AMP** button in sequence, the LCD will display in turn with Battery Voltage, Charging Current, if you do not press the button, the LCD will alternatively display the FUL and VOLT or FUL and AMP every 2 seconds.

8.2.8 v ⇒ 8.0.0 °C or 89.0 A ⇒ 8.0.0 °C

**CHARGING STAGES**

The **VOLT / AMP** button can be changed at any time during charging process.

The LCD also can be treated as an independent voltage meter. A voltage less than 11.5V Volts indicates that the battery is discharged and needs re-charging.

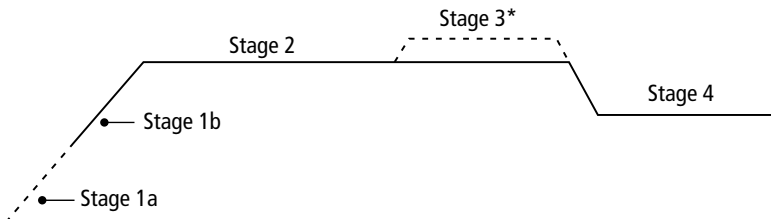

**Soft Charge (Stage 1a)** – When batteries suffer an over-discharge, the controller will softly ramp the battery voltage up to 10V.





**Bulk Charge (Stage 1b)** – Maximum current charging until batteries rise to Absorption level.

**Absorption Charge (Stage 2)** – Constant voltage charging and battery is over 85%.



















**Equalization Charge\* (Stage 3)** – Only for WET battery or Calcium battery type, when the battery is deeply drained below 10V, it will automatically run this stage to bring the internal cells as an equal states and fully complement the loss of capacity (Gel and AGM battery do not run Equalization charge).

**Float Charge (Stage 4)** – When the battery is fully charged it is maintained at a safe level. A fully charged battery has a voltage of 13.6 Volts.

### OPERATION – L.E.D. INDICATION

The 6 LED's indicate the charging status and the battery condition	 Red	 Blue	Green	 Green	 Yellow	 Red
Solar Power Present – No battery connected	ON	OFF	OFF	OFF	OFF	Flash
Soft charging	ON	Flash	OFF	OFF	OFF	ON
Bulk charging	ON	ON	OFF	Subject to battery voltage		
Absorption charging	ON	ON	OFF	ON	OFF	OFF
Equalization charging	ON	ON	OFF	ON	OFF	OFF
Float charging	ON	OFF	ON	OFF	OFF	OFF
Solar panel weak	Flash	OFF	OFF	Subject to battery voltage		
At night no charge	OFF	OFF	OFF	Subject to battery voltage		
Battery Voltage below 11.5V (+/-0.2V)	ON	ON	OFF	OFF	OFF	ON
Battery Voltage between 11.5V - 12.5V(+/-0.2V)	ON	ON	OFF	OFF	ON	OFF
Battery Voltage above 12.5V (+/-0.2V)	ON	ON	OFF	ON	OFF	OFF

### ABNORMAL OPERATION MODE

Solar panel abnormal mode	LCD display	LED indication	LCD backlight
Solar panel weak		 Flash	ON
Solar panel reverse connection		 Flash	Flash
Solar panel over voltage (> 26.5V)		 Flash	Flash
Battery abnormal mode	LCD display	LED indication	LCD backlight
Battery disconnected or less than 3.0V		 Flash  Flash  Flash	Flash
Battery reverse connection		 Flash	Flash
Battery over voltage than > 17.5V		 Flash	Flash
Battery temperature over 65°C		 Flash  Flash  Flash	Flash
Solar controller abnormal mode	LCD display	LED indication	LCD backlight
The controller over temperature protection			Flash

## OPTIONAL EXTERNAL DEVICE

The controller provides an optional devices (not included P/No. SC1TMP).

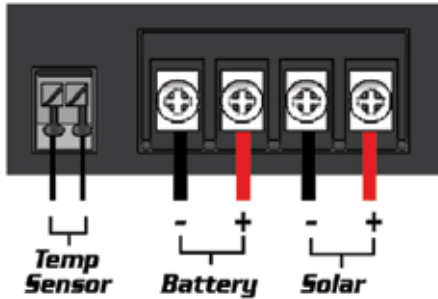

### Optional external Battery temperature sensor:

As an option, the unit provides a port to connect the external battery temperature sensor; If the external battery temperature sensor is connected, the unit will optimize the charging performance subjected to the battery temperature detected and also provide the battery over temperature protection, in some case, if battery over temperature occurs, the controller will automatically stop charging.

## SOLAR CONTROLLER SPECIFICATIONS

<b>1 Electrical Parameters</b>			
1-1	Rated solar panel amps	10	Max. AMP
1-2	Normal input Solar cell array voltage	15-22	VDC
1-3	Max. solar cell array voltage (output has no load)	25	Max. VDC
1-4	The controller lowest operating voltage (at solar or battery side)	8V	Min VDC
1-5	Standby current consumption at night	5	Max mA
1-6	Maximum voltage drop-Solar panel to battery	0.25	Max. VDC
<b>2 Charging characteristics</b>			
2-1	Minimum battery start charging voltage	3	Min VDC
2-2	Soft start charging voltage	3-10	+/-0.2 VDC
2-3	Soft start charging current (50% PWM duty)	Up to 5	AMP
2-4	Bulk charge voltage	10-14.0	+/-0.2 VDC
2-5	Absorption charging voltage at 25°C		
	– Gel type battery	14.1	+/-0.2 VDC
	– AGM type battery (default setting)	14.4	+/-0.2 VDC
	– WET type battery	14.7	+/-0.2 VDC
	– Calcium type battery	14.9	+/-0.2 VDC
2-6	Absorption transits to Equalizing or Float condition:		
	– Charging current drops to	1	+0.1 AMP
	– or Absorption Charging timer timed out	4	Hour
2-7	Equalization charging active (min 1 hr)		
	– Only for WET or Calcium battery		
	– battery voltage discharged to less than	10	+/-0.2 VDC
	– Automatic equalizing Charging periodical	28	Day
2-8	Equalization charging voltage at 25°C	15.5	+/-0.2 VDC
2-9	Equalization charging timer timed out	2	Max Hour
2-10	Float charging voltage at 25°C	13.6	+/-0.2 VDC
2-11	Voltage control accuracy	+/- 1%	
2-12	Battery temperature compensation coefficient	-24	mV/°C
2-13	Temperature compensation range	-20~+50	°C
<b>3 Protection</b>			
3-1	Against reverse polarity or short circuit at panel side		
3-2	Against reverse polarity or short circuit at battery side		
3-3	No reverse current from battery to solar at night		
3-4	Over temperature protection during charging	65°C	
3-5	Transient over voltage protection with TVS or varistor		
<b>4 Electrical parts</b>			
4-1	Input output terminal	M4 terminals	
4-2	Temperature sensor port (Press and Release type)	DA 250-350 2P	
<b>5 Physical Parameters</b>			
5-1	Controller material	Plastic, Standard ABS	
5-2	Power terminal maximum stranded wire size	#12AWG stranded – 3 mm <sup>2</sup>	
5-3	Mounting	Vertical wall mounting	
5-4	IP grade	IP22	
5-5	Net weight	Approx. 250g	
<b>6 Environmental characteristics</b>			
6-1	Operating temperature	-25 ~ 50°C	
6-2	Storage temperature	-40 ~ 85°C	
6-3	Operating Humidity range	100% no condensation	



**NOTES**

**NOTES**

**NOTES**

## **WARRANTY STATEMENT**

Brown & Watson International Pty. Ltd. ("BWI") of 1500 Ferntree Gully Road, Knoxfield, Vic., telephone (03) 9730 6000, fax (03) 9730 6050, warrants that all products described in its current catalogue will under normal use and service be free of failures in material and workmanship for a period of one (1) year from the date of the original purchase by the customer as marked on the invoice (see elsewhere for specific warranty period).

This warranty does not cover ordinary wear and tear, abuse, alteration of products or damage caused by the purchaser.

To make a warranty claim the consumer must deliver the product at their cost to the original place of purchase or to any other place which may be nominated by either BWI or the retailer from where the product was bought in order that a warranty assessment may be performed. The consumer must also deliver the original invoice evidencing the date and place of purchase together with an explanation in writing as to the nature of the claim.

In the event that the claim is determined to be for a minor failure of the product then BWI reserves the right to repair or replace it at its discretion. In the event that a major failure is determined the consumer will be entitled to a replacement or a refund as well as compensation for any other reasonably foreseeable loss or damage.

This warranty is in addition to any other rights or remedies that the consumer may have under State or Federal legislation.

## **IMPORTANT NOTE**

Our goods come with guarantees that cannot be excluded under the Australian Consumer Law. You are entitled to a replacement or refund for a major failure and compensation for any other reasonably foreseeable loss or damage. You are also entitled to have the goods repaired or replaced if the goods fail to be of acceptable quality and the failure does not amount to a major failure.

### **Distributed by**

#### **AUSTRALIA**

**Brown & Watson International Pty Ltd**

Knoxfield, Victoria 3180

Telephone (03) 9730 6000

Facsimile (03) 9730 6050

National Toll Free 1800 113 443

#### **NEW ZEALAND**

**Narva New Zealand Ltd**

22–24 Olive Road

PO Box 12556 Penrose

Auckland, New Zealand

Telephone (09) 525 4575

Facsimile (09) 579 1192