



RA12-33EV (12V33Ah)

RA12-33EV is specially designed for deep cycle discharge and grouping usage in electric vehicle application. By the special active material design in the plate, it makes battery have more than 300 cycles life time by 100% D.O.D. Specially, the consistency performance of grouping usage is much better than general series.



Specification

Cells Per Unit	6
Voltage Per Unit	12
Capacity	33Ah@10hr-rate to 1.75V per cell @25°C
Weight	Approx. 10.2 Kg
Max. Discharge Current	330 A (5 sec)
Internal Resistance	Approx. 9 mΩ
Operating Temperature Range	Discharge: -20°C~60°C Charge: 0°C~50°C Storage: -20°C~60°C
Normal Operating Temperature Range	25°C±5°C
Float charging Voltage	13.6 to 13.8 VDC/unit Average at 25°C
Recommended Maximum Charging Current Limit	9.9 A
Equalization and Cycle Service	14.6 to 14.8 VDC/unit Average at 25°C
Self Discharge	RITAR batteries can be stored for more than 6 months at 25°C. Self-discharge ratio less than 3% per month at 25°C. Please charge batteries before using.
Terminal	Terminal F7/F11
Constainer Material	A.B.S. (UL94-HB), Flammability resistance of UL94-V2 can be available upon request.



MH28539



G4M20206-0910-E-16



ISO9001:2000 Certificate

Dimensions

Unit: mm Dimension: 195(L)×130(W)×180(H)

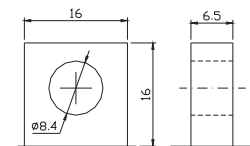
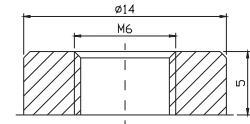
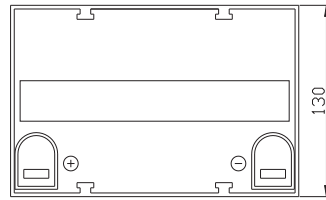
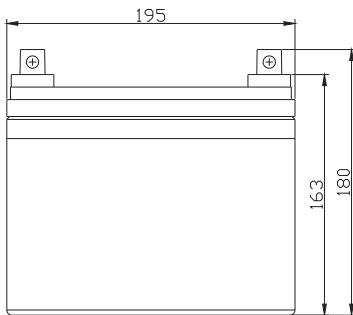

Constant Current Discharge Characteristics: A(25°C)

F.V/Time	5MIN	10MIN	15MIN	30MIN	1HR	2HR	3HR	4HR	5HR	8HR	10HR	20HR
9.60V	115.3	84.9	61.8	38.0	21.5	11.98	8.61	7.13	5.83	4.10	3.47	1.83
10.0V	112.0	80.8	60.5	37.3	21.4	11.89	8.58	7.10	5.80	4.07	3.43	1.80
10.2V	108.7	77.9	59.6	37.0	21.2	11.80	8.51	7.06	5.77	4.03	3.40	1.77
10.5V	97.6	71.9	56.7	36.1	21.0	11.71	8.48	7.00	5.70	4.00	3.37	1.73
10.8V	88.1	65.6	52.3	34.5	20.5	11.50	8.25	6.83	5.59	3.93	3.33	1.70
11.1V	76.7	58.6	46.9	32.3	19.4	10.99	7.89	6.50	5.35	3.77	3.23	1.60

Constant Power Discharge Characteristics: W(25°C)

F.V/Time	5MIN	10MIN	15MIN	30MIN	1HR	2HR	3HR	4HR	5HR	8HR	10HR	20HR
9.60V	1209	903	665	407	245	138	99.4	82.4	67.5	47.6	39.0	20.6
10.0V	1177	862	651	402	244	137	99.2	82.2	67.1	47.4	38.6	20.4
10.2V	1142	834	642	397	242	136	98.6	81.8	66.9	47.0	38.4	20.2
10.5V	1028	770	612	388	240	135	98.0	81.2	66.3	46.6	38.0	20.0
10.8V	925	699	563	370	234	133	95.6	79.0	65.3	45.6	37.6	19.8
11.1V	798	621	502	347	222	127	90.9	75.2	62.0	44.0	36.4	19.0

All mentioned values are average values.

RA12-33EV

12V33Ah



Life characteristics of cyclic use

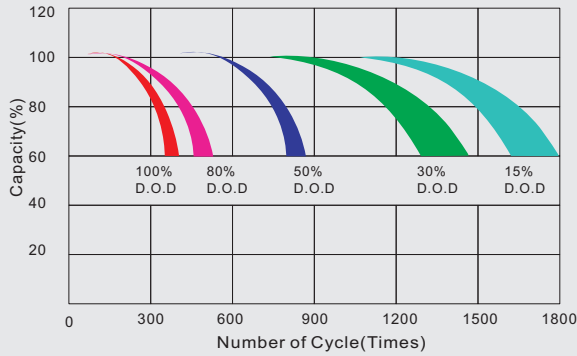

Storage characteristic

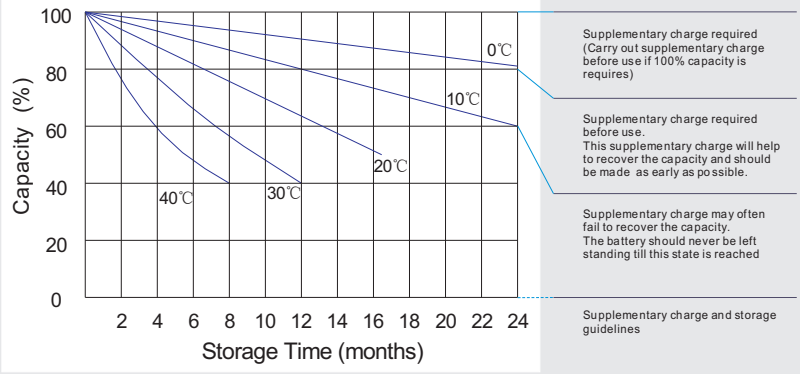

Charge characteristic Curve for standby use

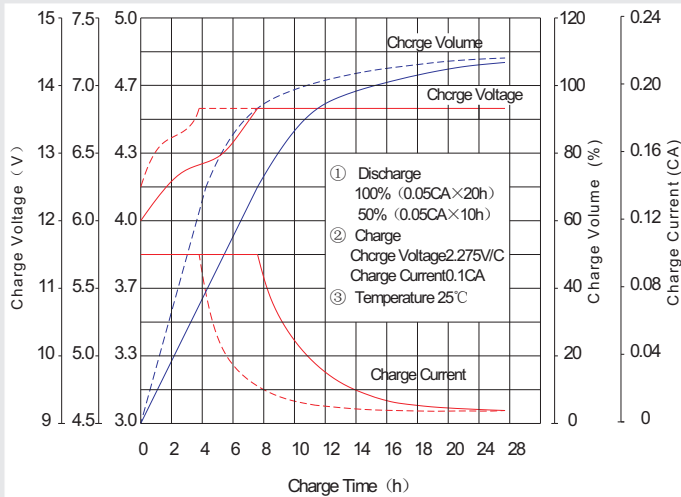

Discharge characteristic Curve

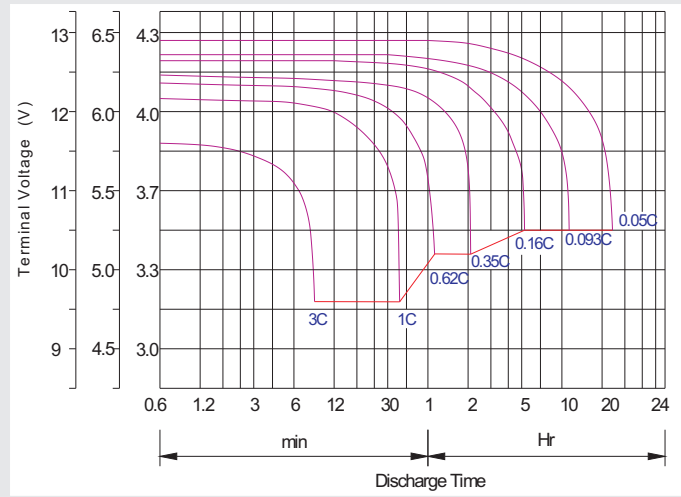

Capacity Factors With Different Temperature

Battery Type		-20°C	-10°C	0°C	5°C	10°C	20°C	25°C	30°C	40°C	45°C
GEL Battery	6V&12V	50%	70%	83%	85%	90%	98%	100%	102%	104%	105%
	2V	60%	75%	85%	88%	92%	99%	100%	103%	105%	106%
AGM Battery	6V&12V	46%	66%	76%	83%	90%	98%	100%	103%	107%	109%
	2V	55%	70%	80%	85%	92%	99%	100%	104%	108%	110%

Discharge Current VS. Discharge Voltage

Final Discharge Voltage V/cell	1.75V	1.70V	1.60V
Discharge Current (A)	(A) ≤ 0.2C	0.2C < (A) < 1.0C	(A) ≥ 1.0C

Maintenance & Cautions

Charge the batteries at least once every six months, if they are stored at 25°C.

Charging Method:

Constant Voltage	-0.2Cx2h+2.4~2.45V/Cellx24h, Max. Current 0.3CA
Constant Current	-0.2Cx2h+0.1CAx12h
Fast	-0.2Cx2h+0.3CAx4.0h

Cycle service
※ Avoid battery over discharge, especially battery series connection use.
※ Charged with recommend voltage, ensure battery can be full recharged.
In general, recharge capacity should be 1.1-1.15 times discharge capacity.
※ Effect of temperature on cycle charge voltage: -4mV/°C/Cell.
※ There are a number of factors that will affect the length of cyclic service.
The most significant are depth of discharge, ambient temperature, discharge rate, and the manner in which the battery is recharged.
Generally speaking, the most important factors is depth of discharge.