

## Troubleshooting

**AC Power LED** (blue), Charge Mode **LED** or Charge Monitor **LEDs** are not **ON**.

Check for loss of AC power at the 240 VAC outlet. Confirm GFCI (Ground Fault Circuit Interrupter) has not tripped. Check with a meter or 240 VAC test light that AC power is present at the end or in your extension cord. Reset AC power if it was not present. Confirm all charger cables are installed with the correct polarity connections at each battery and that all connections are clean and tight. Wait for 2 minutes until the unit completes analyzing stage.

**System Check OK LED** (green) is **OFF** and Troubleshoot **LED** (bank1, bank2 or bank3) is **ON** (red).

Identify the battery bank LED that is lit, remove AC power and check the battery bank indicated, for example bank 1, bank 2 or bank 3 (model specific). The LED indicates there is a fault present. Below are listed typical faults and instructions on how the fault status can be solved:

Note: After making any corrections, reapply AC power.

**Poor battery connections** - Make sure all connections are tight and clean.

**Blown DC cable fuse** - Use the ohm meter or continuity tester to make sure all fuses are healthy and visually inspect the DC battery cables to ensure they have not been compromised or shorted in any manner.

**Reverse polarity** - Make sure all wiring connections are color coded and connected properly and that each bank cable goes to one 12V battery where (+) = red and (-) = black.

**Battery too low to charge** - Using a digital voltmeter, make sure the battery is over 2.5 volts DC. If not, have your battery charged out of the boat and have it load tested by your local battery dealer to ensure it is safe to charge and that the battery is capable of holding a charge.

**High battery voltage input** - Make sure a bank lead has not been spread across 2 batteries connected in series for 24 volts DC. If so, correct by following the wiring diagrams on pages 13-20.

**Battery(s) not charging, AC Power LED** (blue), Charge Mode **LED** (red) and Battery Monitor **LEDs** are **ON**

Confirm all charger cables are installed with the correct polarity connections at each battery, and that all connections are clean and tight. Confirm that there are no bank Battery Trouble Status LED indicators on. With the charger on, read DC voltage at each battery. If any of the readings are less than 12.8 volts DC, proceed with the following:

A. Disconnect AC power at the 240 VAC outlet.

B. Refer to pages 13-20 in this manual and confirm your charger is connected correctly to the battery based on the wiring diagram in Installation section.

C. After completing step B, plug your charger into AC power and observe the LED display. Charger should be in the charging mode (charging LED under Charge Mode is red). In case the batteries were completely depleted, after completing a full charging cycle that may take up to 10~12 hours or more, maintaining LED (green) under Charge Mode and 5 Charge Monitor LEDs (green) are also illuminated.

Note: If a Digital Volt Meter (DVM) is available to you, instead of waiting to complete a full charging cycle, you can simply use a DVM and take DC voltage measurements across each 12 volts battery. As long as the voltage continues to increase while the fast charging LED (red) under Charge Mode is on, this will serve as a confirmation that the charger is properly connected and is properly charging.

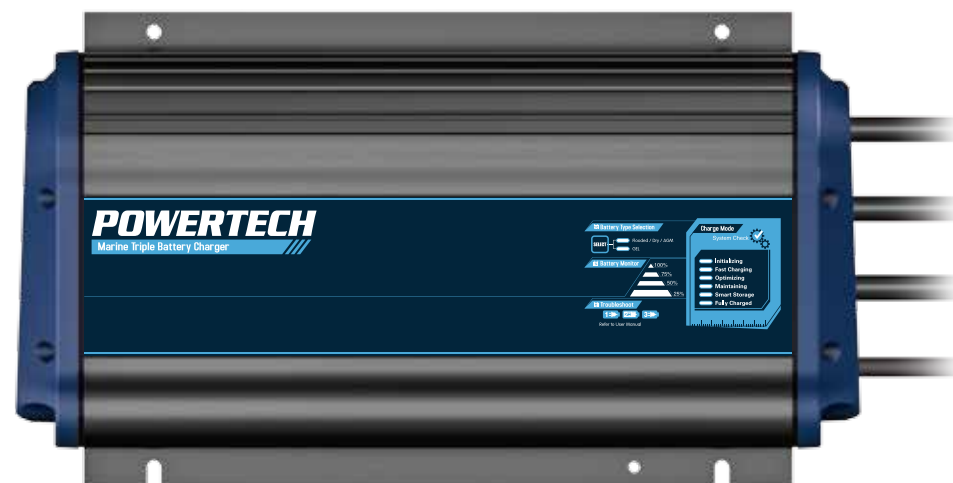

## Battery Charger

Models	Volts*	Amps	Max. qty of 12V Batteries	AC in
MB3616 12 Amp	12	12	2	240VAC +/-10% 50 Hz
MB3617 20 Amp	12	20	3	240VAC +/-10% 50 Hz

\*For use with trolling motor DC voltages.

### IMPORTANT INFORMATION

Make sure to save and read all safety, operating and installation instructions prior installing or applying AC power to your Battery Charger.

This product is designed for 12 Volt Flooded and AGM (Absorbed Glass Mat) Lead Acid batteries. Do not use with any other type of batteries, such as 4D and 8D large capacity batteries. For other applications, please refer to our website.

### Specification

#### MB3616

Input Voltage: 240VAC  
 Output Voltage: 12/24V  
 Input Current: 1.89A  
 Output Current: 12A @ 12VDC  
 6A @ 24VDC

Efficiency: 80%  
 IP Rating: IP68  
 Cable Length: 1.8m  
 Dimensions: 262(L) x 176(W) x 72(H)mm

#### MB3617

Input Voltage: 240VAC  
 Output Voltage: 12/24/36V  
 Input Current: 3.13A  
 Output Current: 20A @ 12VDC  
 10A @ 24VDC  
 6.6A @ 36VDC

Efficiency: 80%  
 IP Rating: IP68  
 Cable Length: 1.8m  
 Dimensions: 321(L) x 176(W) x 72(H)mm

## MAINTENANCE

Item:	<i>AC Power Cord</i>
Process:	Visually inspect the AC power cord. Confirm ground blade is present and all plug blades are in good condition and not bent out of place.
When:	Monthly
Item:	<i>Mounting Hardware Inspection</i>
Process:	Check all mounting hardware to ensure there is no loose hardware. Tighten where required.
When:	Monthly
Item:	<i>Battery Connections</i>
Process:	Clean and tighten all battery connections. Follow battery manufacturer's instructions for cleaning a battery, Clean all battery terminals with a wire brush where required and tighten all battery connections
When:	Monthly
Item:	<i>Battery Electrolyte</i>
Process:	Per battery manufacturer's instructions, monitor, and maintain proper levels of distilled water in each battery.
When:	Monthly
Item:	<i>DC Output Wiring</i>
Process:	Visually inspect all wiring for cuts and abrasions. Contact us if your charger needs to be serviced.
When:	Monthly

## Introduction

Thank you for purchasing the Marine Battery Charger. Our products have been designed and manufactured to meet the harsh environmental, mechanical and electrical conditions that are present in the marine industry. We are happy to introduce you our battery charger, boasting a clean geometric design executed with a heavy duty extruded aluminum housing thus providing increased power and performance. Your battery charger incorporates digitally controlled performance charging technology proven to fully charge and extend the life of your batteries.

### **All-Digital Technology for Enhanced Performance**

Microprocessor and software controlled pulse charging technology helps to deliver cooler charging process and faster charging.

### **Fully Automated Multistage Digital Charging**

Involves 5 stages, such as analyzing, charging, examining the conditions, auto maintaining and reconditioning batteries once a month. This 5-stage charging method helps to fully charge and extend your battery life. As well as provide safe operation for both short and long term storage periods.

### **Digital Charging Monitoring**

Monitors charging level progress during the charging operation. Single red LED indicates charging low battery(s).

### **System Check OK Indication**

During AC power-on, the battery charger analyzes and confirms with the System Check OK indicator that the charger is wired correctly, batteries are greater than 2.5 VDC and are able to be charged.

### **Battery Fault Detection**

Avoids time consuming troubleshooting and clearly indicates wiring faults of each battery or if a battery is less than 2.5 VDC and unable to accept charge.

### **LED Charging Display**

Highly visible AC Power and status LEDs indicating the progress of each 5 modes, such as Initializing, fast charging, optimizing, maintaining and smart storage.

### **Integrated Highly Efficient output distribution Technology**

We have designed our battery chargers to automatically sense and provide 100% of available charging amps to any or all of the banks as needed. All unused charging amps are Distributed- On-Demand™ to batteries on board that require additional charging amps.

### **Energy Saving Mode**

After batteries are fully charged and conditioned, the charger will observe and auto maintain batteries only if needed to maintain a full state of charge. This reduces remarkably AC power consumption and lowers operating costs while maximizing the battery performance.

### **High Quality and Safety**

Heavy duty extruded aluminum housing and In-line DC fuses for all battery banks. Over-voltage, overload, over-temperature, reverse polarity and ignition protection. Designed and assembled to meet the requirements of SAA C-Tick certificate

### **Easy Setup and Operation**

Pre-wired with 6 feet AC and DC cables

### **1-Year Warranty**

Applicable only if the charger has been operating with 12 volts Flooded and AGM Lead Acid batteries.

Introduction	1-2
CAUTIONS, WARNINGS AND SAFETY INSTRUCTIONS	3-7
General Overview	8
Getting Started	9-10
Installation	11-13
Typical Wiring	14-20
Charging your Batteries	21
Maintenance	22
Troubleshooting	23

### Important Charger Operation Note:

After your battery charger is installed and properly connected to the batteries, you will be ready to plug it to the electrical outlet.

Your battery charger performs charging in 5 stages. The first stage is initializing, all battery connections and batteries to ensure your boat's batteries are capable of being charged safely and in a proper manner. The charger enters into initializing mode every time it is plugged into a GFCI protected 0 VAC outlet. The self-test will take up to 2 minutes to complete.

In analyzing mode, the LED under Fast Charge Mode will be flashing red. In the condition that all batteries are connected properly, are healthy and above 2.5 volts DC, your charger will register and illuminate the green System Check OK LED. Next the charger enters fast charging mode. The charging LED under Fast Charge Mode lights solid red and you can monitor the charging progress by checking the Charge Monitor LEDs' color changing from red to green. After the charging LED under Charge Mode turns OFF, the system enters Optimizing stage and respectively the Optimizing LED lights solid amber. In this mode the batteries are kept at 14.6 VDC up to 3 hours per battery if necessary. When charging is done, the Maintaining LED under Charge Mode lights green, indicating the batteries are fully charged.

In case the charger does not enter the fast charging mode and the respective fast charging LED under Charge Mode is not solid red and the System Check OK LED is not solid green, then examine the following:

Are any of the bank LEDs under Battery Bank Trouble LED solid red, indicating the battery(s) have either a wiring fault present, such as poor connection, blown DC cable fuse, the DC cable is wired in reverse polarity, battery cable is wired across two batteries in series with a high DC over-voltage of 24V or the battery itself may be under 2.5 volts DC. If any of the above situations occur, refer to the Troubleshooting section in this manual.

Your battery charger is designed to charge, condition, and auto maintain your batteries during short or long term periods of storage or non use. Please follow these steps each time you use your charger:

1. Please read through the manual to understand the warnings.
2. Ensure the charger is installed exactly as described in installation instructions.
3. Connect a heavy duty UL approved extension cord to your battery charger first. After connecting the extension cord to the charger, proceed to plug the extension cord to a nearby 240 VAC GFCI protected (Ground Fault Circuit Interrupt) outlet. After power is supplied to the charger, the Power LED lights solid blue.
4. Then the analyze LED under Charge Mode starts flashing red, indicating the charger is in analyze state. **Analyzing may take up to 2 minutes and is followed by the self test where all wired connections, battery type (has to be > than 2.5 Volts DC) and battery's ability to accept charge is checked for faults. Assuming there are no battery faults, the System Check OK LED lights solid green and the charging operation begins:**

*Note: If there is a bad connection, reverse polarity, or a battery that is below 2.5 VDC that can not accept a charge then the Battery Trouble Status LED lights solid red for the battery that requires attention. See page 26 for further troubleshooting details.*

5. The charging LED under Charge Mode lights solid red and stays illuminated throughout the whole charging process, indicating the charger has started its multi-stage charging procedure. For more information, please see Multi-Stage Charging Overview section in this manual.

**Note:** While charging, observe the Charge Monitor LED to check the battery charging progress.

6. Then the charging LED under Charge Mode turns off and the conditioning LED under Charge Mode lights solid amber, indicating that the charger is holding all batteries at 14.6 VDC and is conditioning each battery for up to 3 hours if necessary.
7. When the charging process is complete (or if your batteries are fully charged when you apply AC power) the auto maintain LED under Charge Mode starts blinking green (Energy Saving Mode), indicating your batteries are fully charged.

**Fig. 7 One Bank Charger for one 12V Battery**

Dedicated 12 VDC Trolling Motor, House or Engine Battery Configuration

Note:  
 Indicates Jumper Series  
 Indicates Fuse

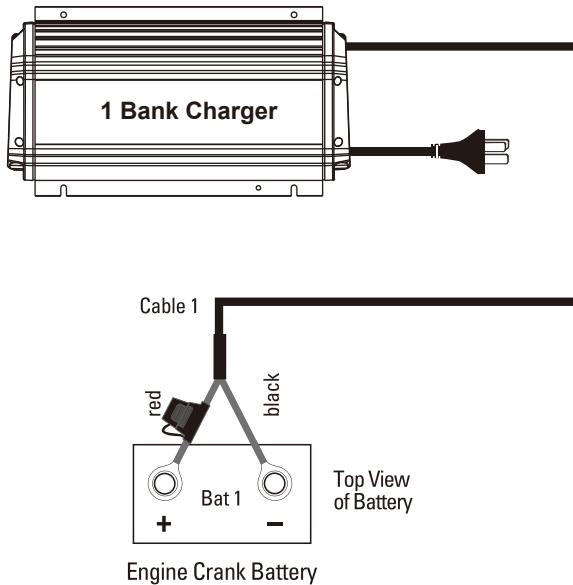

**Installation**

When connecting each jacketed battery charger cable, make sure it is connected to only **one 12 VDC battery** and observe the polarity and color of all connections:

- Red Wire to the “+” (Positive) Battery connection
- Black Wire to the “-” (Negative) Battery connection

The black wire can never be connected to a terminal with red wires and vice versa.

**Important: The pair of red and black wires in 1 cable jacket MUST GO TO THE SAME 12VDC battery.**

**Important Safety Instructions**

**ⓘ ABOUT SAFETY INSTRUCTIONS**

The important safety and operating instructions described in this manual apply for the Battery Charger.

**⚠ CAUTION** - To minimize the risk of injury, charge only 12V Flooded and AGM lead acid batteries. Other types of batteries may burst, causing personal injury.

EXTERNAL CONNECTIONS TO CHARGER SHALL COMPLY WITH THE REGULATION.

Before connecting your batteries or applying AC power, please read all instructions and cautionary markings on the battery charger, cables, and batteries.

**⚠ WARNING**

To minimize the risk of injury to the user or property, before using the charger for the first time, make sure to read and understand all the instructions and warnings described in this manual as well as the ones written directly on the charger and batteries.

**⚠ WARNING**

1. **WARNING - RISK OF EXPLOSIVE GASES.**
  - a. **WORKING IN THE VICINITY OF A LEAD-ACID BATTERY IS DANGEROUS. BATTERIES GENERATE EXPLOSIVE GASES DURING NORMAL BATTERY OPERATION. FOR THIS REASON, IT IS OF UTMOST IMPORTANCE THAT YOU FOLLOW THE INSTRUCTIONS EACH TIME YOU USE THE CHARGER.**
  - b. To minimize the risk of battery explosion, make sure to follow the instructions provided in this manual as well as the ones written directly on the battery.
2. Use the charger for charging LEAD-ACID battery only. The Marine Battery Charger is not designed to supply power to an extra - low - voltage electrical system or to charge dry-cell batteries. Charging dry-cell batteries may burst and cause injury to persons and property.
3. To reduce the risk of damage to the electric plug and cord, always pull the cord by the plug rather than the cord when disconnecting from the mains.
4. Extension cords:
  - a. All the pins on the plug of the extension cord are exactly the same number, size and shape as the ones on the plug of the charger.
  - b. Use only a properly wired extension cord in good electrical condition.
  - c. Use an industrial grade / heavy duty UL or CSA approved and grounded extension cord. Before use make sure the extension cord has no cuts, is not damaged and prongs are not bent. Replace immediately if damaged. Always make your extension cord connection on the charger side first.

## Safety Instructions

After connecting the extension cord to the charger, proceed to plug the extension cord into a nearby 240 VAC GFCI protected (Ground Fault Circuit Interrupt) outlet.

Below are manufacturer suggestions for the right size UL or CSA Approved grounded extension cord.

- i. Up to 50 feet in length use a 3 conductor 18 AWG extension cord.
  - ii. 50 to 100 feet in length use a 3 conductor 16 AWG extension cord.
  - iii. 100 to 150 feet in length use a 3 conductor 14 AWG extension cord.
5. Stop operating the charger immediately if any protective AC and DC cable insulation, DC fuse holders or ring terminals have been damaged or compromised. Contact the manufacturer to return the charger for service and repair. For contact information, please see the Warranty section.
  6. Stop operating the charger immediately if it has received a sharp blow, direct hit of force, been dropped or otherwise damaged in any manner. Contact the manufacturer to return the charger for service and repair.
  7. Avoid disassembling the charger. Incorrect reassembly may result in a risk of electric shock or fire. Unauthorized attempts to service, repair or modify may result in a risk of electrical shock, fire or explosion and will void the warranty.
  8. To minimize the risk of electric shock, unplug the charger from the electrical outlet before performing any maintenance or cleaning.
  9. Do not expose AC power cord connection to the rain or snow.
  10. **GROUNDING AND AC POWER CORD CONNECTION INSTRUCTIONS**
    - a. The charger should be grounded to reduce the risk of electric shock. The charger is equipped with an electric cord having in equipment - grounding conductor and a grounding plug. The plug has to be plugged into a **240 VAC GFCI protected (Ground Fault Circuit Interrupt) outlet** that is properly installed and grounded in accordance with all local codes and ordinances.

### **⚠ DANGER**

Never alter manually the supplied AC cord or plug - If the cord does not fit the electrical outlet, have proper outlet installed by a qualified electrician. Improper connection can result in a risk of an electric shock.

- i. This battery charger is for use on a nominal 240-volts circuit, and has a grounding pin as illustrated in figure A. A temporary adapter that is illustrated in figure B can be connected to a two-pole receptacle in figure B if a properly grounded outlet is not available. **The temporary adapter should be used only until a properly grounded GFCI protected outlet can be installed by a qualified electrician.**

### **⚠ DANGER**

Prior using the adapter as illustrated in Figure A and Figure B, make sure that the

## Typical Wiring

Fig. 6 Two Bank Charger for two 12V Batteries in Parallel

Dedicated 12 VDC Parallel Trolling Motor or House Configuration

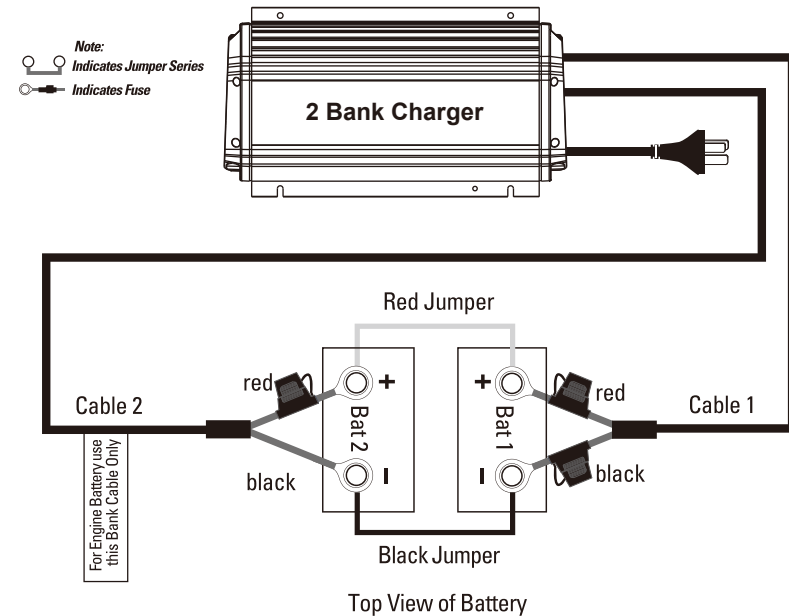

### Installation

When connecting each jacketed battery charger cable, make sure it is connected to only **one 12 VDC battery** and observe the polarity and color of all connections:

- Red Wire to the “+” (Positive) Battery connection
- Black Wire to the “-” (Negative) Battery connection

The black wire can never be connected to a terminal with red wires and vice versa.

**Important: The pair of red and black wires in 1 cable jacket MUST GO TO THE SAME 12VDC battery.**

**Fig. 5 Two Bank Charger for two 12V Batteries**

Dedicated **24 VDC** Trolling Motor Battery Configuration with (2) **12 VDC** batteries Connected with a Series Jumper

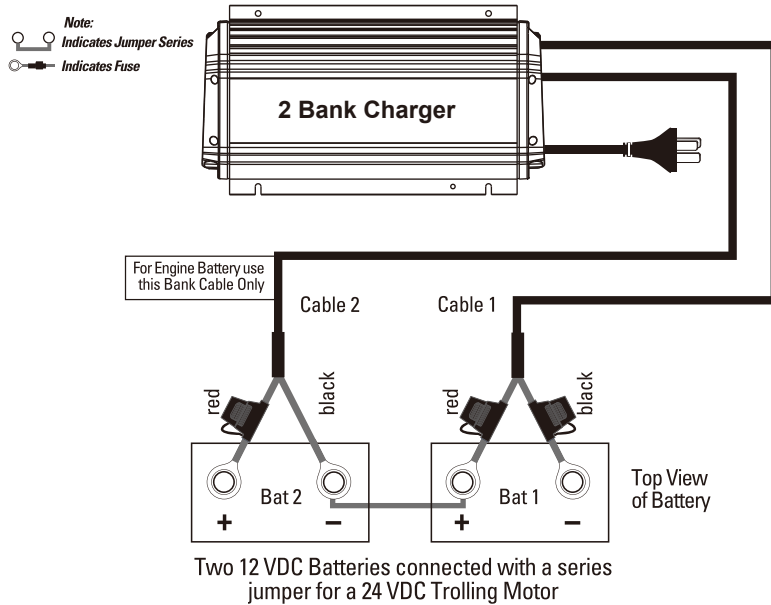

**Installation**

When connecting each jacketed battery charger cable, make sure it is connected to only **one 12 VDC battery** and observe the polarity and color of all connections:

- Red Wire to the “+” (Positive) Battery connection
- Black Wire to the “-” (Negative) Battery connection

The black wire can never be connected to a terminal with red wires and vice versa.

**Important: The pair of red and black wires in 1 cable jacket MUST GO TO THE SAME 12VDC battery.**

screw in the center of the outlet plate is grounded. The green-colored rigid ear or lug extending from the adapter must be connected to a properly grounded outlet. If necessary, replace the original outlet cover plate screw with a longer screw that will better secure the adapter ear or lug to the outlet cover plate and enable grounding the connection to the grounded GFCI protected outlet.

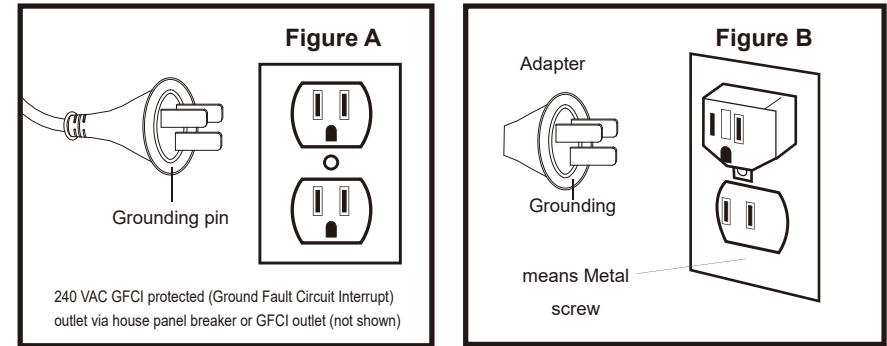

**11. PERSONAL PRECAUTIONS**

**⚠ CAUTION**

- Make sure there is someone close enough or within the range of your voice to come to your aid when you work near a lead-acid battery.
- Have plenty of soap, water and baking soda nearby in case the battery acid comes in contact with your skin, clothes or eyes.
- Wear complete eye protection, hand and clothing protection. Avoid touching eyes while working near a battery.
- If the battery acid contacts skin or clothing, rinse immediately with plenty of soap and water. If acid enters the eye, immediately flood eye with running cold water for at least 15 minutes and seek for medical assistance. If electrolyte is taken internally, drink large quantities of water or milk. **DO NOT** induce vomiting. Get prompt medical attention.
- NEVER** smoke, strike a match or cause a spark or flame in vicinity of battery or engine.
- Be extra cautious to reduce risk of dropping a metal tool onto the battery. It might spark or short-circuit a battery or other electrical hardware which may result in an explosion or fire.
- Remove all personal metal items such as rings, bracelets, necklaces, watches, and jewelry before working near a battery. A battery can produce a short circuit with current high enough to weld a ring or any other metal, causing serious burns.
- Use charger for charging a LEAD-ACID battery only. It is not intended to supply power to a low voltage electrical system other than in a start-motor application. Do not use the battery charger for charging dry-cell batteries that are commonly used with home appliances. These batteries may burst and cause injury to persons and damage to the property.

## Safety Instructions

- i. NEVER charge a frozen, damaged or leaking battery.
- j. Keep other persons, children and pets away from the batteries and your charger during its operation to avoid serious injury, death, fire or explosion.

### 12. PREPARING TO CHARGE A BATTERY

#### ⚠ CAUTION

- i. If necessary to remove a battery from a boat to charge, **always remove the grounded negative terminal from the battery first**. Make sure all accessories in the boat are off, as to avoid causing an arc.
- ii. Be sure the area around the charger and batteries is well ventilated while the battery is being charged.
- iii. Neutralize with baking soda any electrolyte that spills on a vehicle or in the work area. After neutralizing, rinse the contaminated area clean with water
- iv. Regularly clean the battery terminals. Be careful to keep corrosion from coming in contact with eyes.
- v. For flooded batteries with removable caps, **ONLY ADD DISTILLED WATER** in each cell until electrolyte reaches levels specified by the battery manufacturer. Do not over fill. For a maintenance free battery without removable caps, such as valve regulated lead acid batteries, carefully follow manufacturer's recharging instructions.
- vi. Study all battery manufacturers' specific precautions; warnings and instructions while charging and recommended rates of charge. Never charge a battery with missing safety vent caps.
- vii. Do not overcharge batteries trying to charge non 12 volts flooded or AGM lead acid batteries.

**Completely disconnect the charger after charging. Always remove the extension cord from the 240VAC outlet first when charging is completed followed by unplugging the charger.**

### 13. Charger Location & DC Connection

#### a. CHARGER LOCATION

#### ⚠ CAUTION

- i. Place the charger as far away from the batteries as possible .
- ii. Never place the charger directly above a battery being charged; gases or fluids from the battery will corrode and cause damage to the charger.
- iii. Do not operate the charger in an enclosed area or in an area with restricted ventilation.
- iv. Never allow battery acid to drip on charger when reading electrolyte specific gravity or filling a battery.
- v. Do not place a battery on top of the charger.
- vi. Do not install the charger on or over combustible surfaces.

## Typical Wiring

**Fig. 4 Two Bank Charger for two 12V Batteries**

**12 VDC Trolling Motor or House Battery Configuration with a Dedicated 12 VDC Engine Start Battery**

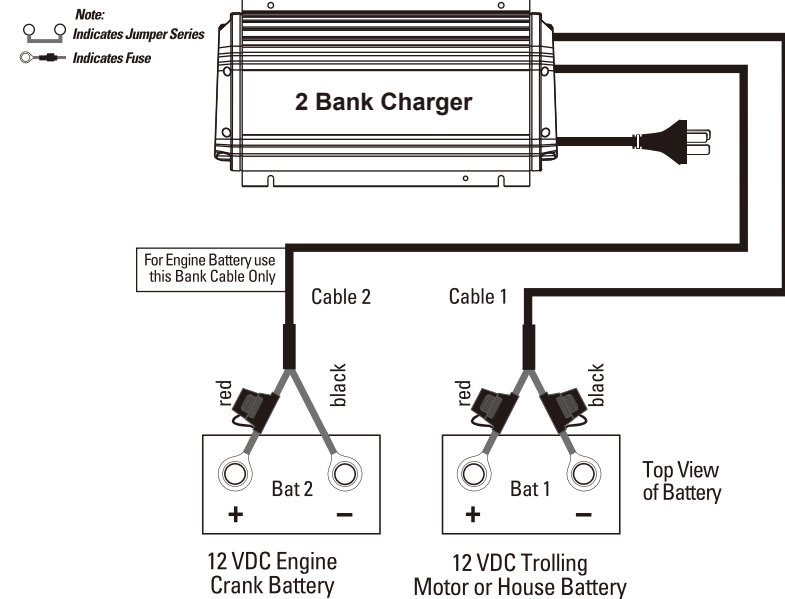

#### Installation

When connecting each jacketed battery charger cable, make sure it is connected to only **one 12 VDC battery** and observe the polarity and color of all connections:

- Red Wire to the "+" (Positive) Battery connection
- Black Wire to the "-" (Negative) Battery connection

The black wire can never be connected to a terminal with red wires and vice versa.

**Important: The pair of red and black wires in 1 cable jacket MUST GO TO THE SAME 12VDC battery.**

**Fig. 3 Three Bank Charger for three 12V Batteries**

Dedicated **36 VDC** Trolling Motor Battery Configuration with (3) **12 VDC** Batteries  
Connected with (2) Series Jumpers

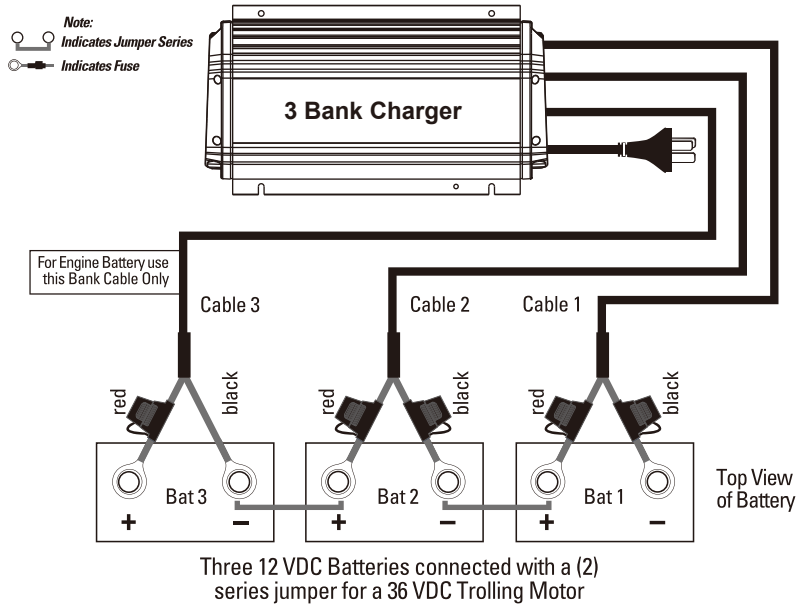

**Installation**

When connecting each jacketed battery charger cable, make sure it is connected to only **one 12 VDC battery** and observe the polarity and color of all connections:

- Red Wire to the “+” (Positive) Battery connection
- Black Wire to the “-” (Negative) Battery connection

The black wire can never be connected to a terminal with red wires and vice versa.

**Important: The pair of red and black wires in 1 cable jacket MUST GO TO THE SAME 12VDC battery.**

**b. DC CONNECTION PRECAUTIONS**

**⚠ CAUTION**

- Connect and disconnect the DC output cables only after removing AC cord from an electric outlet. Never allow the cables to touch each other.

**IMPORTANT NOTICE: C-Tick**

Your Battery Charger has been designed and tested to comply with C-Tick . These regulations are to provide adequate protection against harmful interference while operated in a commercial application. If in a residential setting, you are encountering interference with TV and radio reception, simply remove AC power from the unit to confirm if your battery charger is causing interference. End user can explore the following to minimize interference:

- 1) Choose a different AC circuit to power on your battery charger.
- 2) Make sure your outlet is properly grounded.
- 3) Re-position receiving antenna.
- 4) Purchase a separate AC line filter.
- 5) Place the charger to the furthest point from the home wireless equipment, TV,radio, etc.



## General Overview

Your battery charger features a clean geometric design executed with a heavy duty extruded aluminum housing allowing for increased power and performance. Incorporation of microprocessor and software control adds the latest pulse charging technology resulting in cooler operation and faster charge times. Your charger is fully automatic with a multi-stage digital performance charging profile that includes 5 sequential stages: Initializing, Fast Charging, Optimizing, Maintaining, Smart storage; that is safe for short and long term storage. This process will not only enhance the performance of all 12 volts flooded and AGM lead acid batteries, it will also extend the lifetime of the batteries.

For the ease of use, the battery charger features a brand new intuitive user interface display with individual LED indicators for each charging mode, AC power-on diagnostics with a system check OK status indicator providing positive confirmation that the charger connections are healthy and that the batteries can be charged. The Digital Charge Monitor gauge indicates charging status progress during the operation with a single red LED, indicating low battery(s) are being charged. Dedicated battery fault indicators eliminate time consuming troubleshooting and clearly indicate individual battery wiring faults or if a battery is less than 2.5 VDC and cannot accept a charge.

Our chargers automatically senses and distributes 100% of available charging amps to any or all of the banks as needed..

Energy Saving Mode: after fully charging and conditioning batteries, your charger will monitor and maintain batteries automatically only when needed to keep their full state of charge. This significantly reduces AC power consumption and lowers operating costs while maximizing battery performance.

The Battery Charger is compact, lightweight and prewired for each installation. The charger is 100% waterproof. Built with peace of mind safety every unit incorporates In-line DC fuses for all battery banks, over-voltage, overload, over-temperature, reverse polarity and ignition protection.

## Typical Wiring

Fig. 2 Three Bank Charger for three 12V Batteries

24 VDC Trolling Motor or House Battery Configuration with (2) 12 VDC Batteries Connected with a Series Jumper Plus Dedicated 12 VDC Engine Start Battery

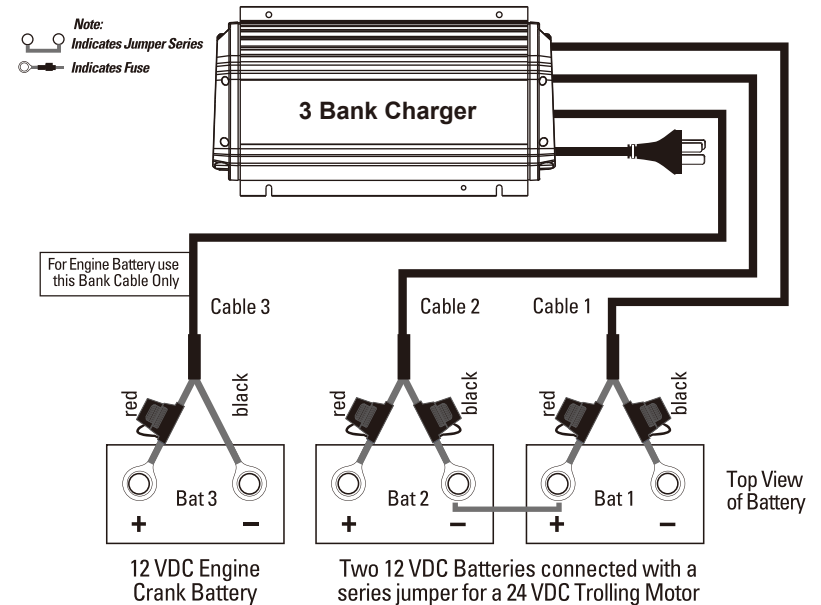

### Installation

When connecting each jacketed battery charger cable, make sure it is connected to only **one 12 VDC battery** and observe the polarity and color of all connections:

- Red Wire to the "+" (Positive) Battery connection
- Black Wire to the "-" (Negative) Battery connection

The black wire can never be connected to a terminal with red wires and vice versa.

**Important: The pair of red and black wires in 1 cable jacket MUST GO TO THE SAME 12VDC battery.**

**Fig. 1 Three Bank Charger for three 12V Batteries**

Dedicated **12 VDC** Trolling Motor or House Battery and 2 Engine Crank Batteries  
Typical Configuration

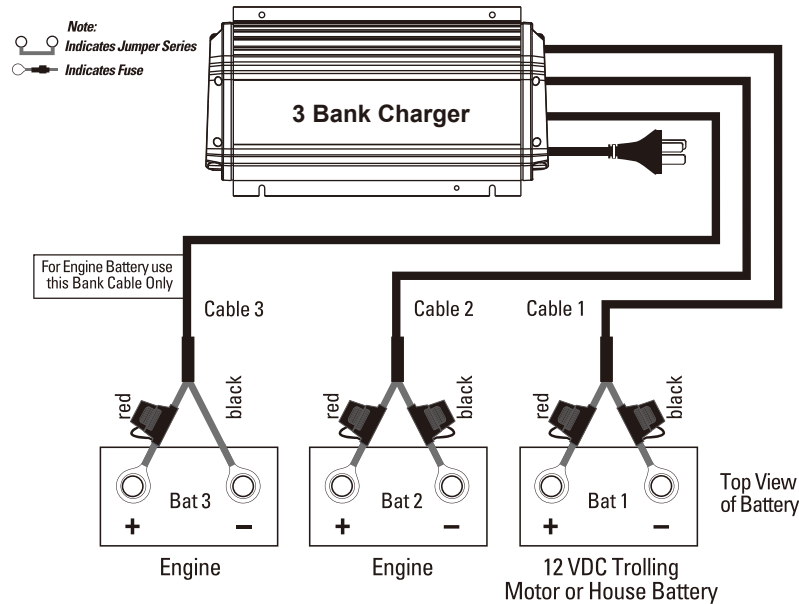

**Installation**

When connecting each jacketed battery charger cable, make sure it is connected to only **one 12 VDC battery** and observe the polarity and color of all connections:

- Red Wire to the “+” (Positive) Battery connection
- Black Wire to the “-” (Negative) Battery connection

The black wire can never be connected to a terminal with red wires and vice versa.

**Important: The pair of red and black wires in 1 cable jacket MUST GO TO THE SAME 12VDC battery.**

Follow the guidelines provided in this manual to install your Battery Charger.

The battery charger will automatically fully charge and condition your batteries to ensure your batteries last a long time and you get the most out of them. When you are not at home, always leave your charger plugged in to reduce sulfate build-up allowing your batteries to be fully charged and automatically maintained for your next fishing trip.

The design of the charger incorporates a storage recondition mode that stimulates and re-conditions your on-board batteries for 3 hours once a month and when completed will resume its normal energy saver auto maintain mode. During this mode the storage recondition LED under Charge Mode will illuminate green but with a fade-in fade-out pulse, indicating storage recondition mode is active with the green auto maintain LED under Charge Mode still illuminated, indicating your batteries remain fully charged during this process.

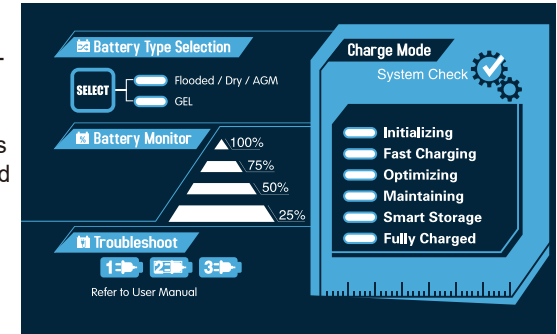

**The LED Display and Charge Monitor**

The battery charger includes 6 LEDs for operation status (Charge Mode, Charge Monitor, and System Check), up to 3 battery bank fault LEDs (bank1, bank2 and bank3 under Battery Trouble Status) depending on the model, battery type selection LED.

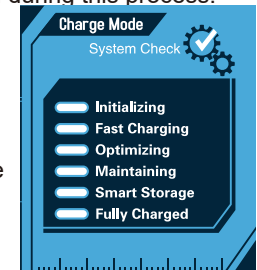

**Overview of the Charge Mode Indicators**

Each LED will sequentially illuminate after the previous mode is completed.

**Initializing LED (Blue):**After the installation of the charger is complete and you have supplied the AC power to the unit, the Initializing LED starts flashing blue, indicating that the charger is in process of Initializing . The Initializing procedure involves checking the connections, polarity and that the battery(s) connected are over 2.5 VDC and are able to accept a charge.

The Initializing stage may take up to two minutes.

**System Check LED (solid green) :** If all tests have passed successfully, the System Check LED lights solid green, indicating your charger is installed properly and your batteries are capable of being charged followed by the charging process.

**Fast Charging LED (solid red):** During charging the fast charging LED lights solid red.

**Optimizing LED (solid amber):** During optimizing the Optimizing LED lights solid amber.

**Maintaining - Energy Saving Mode LED (solid green):** Maintaining LED lights green, indicating the batteries are being monitored to automatically maintain your fully charged battery(s) during short or long term storage periods.

## Getting Started

**Smart Storage LED (pulsing green):** Smart Storage green LED fades in and out when performing the storage recondition procedure to your battery(s)

### Battery Monitor LED (solid green or red)

The Charge Monitor has four green LEDs and one dual color green/red LED. During the first phase of charging when the batteries are depleted, the first LED bar lights solid red, indicating the batteries being charged are low.

As the charging progresses, the first LED bar will transition to green followed by the remaining 4 additional LED slight green.

When all 5 charging LEDs light green it means the batteries are fully charged.

This feature provides an indication of the charging status so that you can quickly see the battery charging level.



### Troubleshoot LED (solid red)

Depending on the model, up to three red LEDs (bank1, bank2 or bank3) may light red, indicating a wiring problem or fault with any of the individual battery(s) connected to the charger.

The Battery Trouble Status LED can also indicate if the battery that is being charged is under 2.5 VDC and requires additional testing by your local battery dealer before trying to charge it.



### Fully Automatic Charging Profile

Your Battery Charger is designed to charge all 12 Volts Flooded and AGM Lead Acid batteries.

Battery Types	Charging Profile
All 12 Volt Flooded (sealed maintenance free or with vent caps) and AGM (Absorbed Glass Mat) Lead Acid Batteries)	14.6 VDC Absorption (Optimizing) and up to 13.4 VDC Float (Maintaining mode).

Note: If you are not sure what kind of battery(s) you have, please consult with the manufacturer of the battery(s).

After completing the installation of your charger, making sure there are no wiring or connection errors, and the battery(s) connected are > 2.5VDC and can be charged, the charger will sequentially perform the following 5-Stage Digital Performance Charging Process: Initializing, Fast Charging, Optimizing, Maintaining, Smart storage

## Installation

### Instructions on Wiring your Charger

The wiring diagrams slightly vary depending on how many banks the charger model supports. To find the correct wiring diagram that matches with your battery charger model, choose the illustration that has the same number of charger output bank cables as your battery charger in hand and wire exactly as shown (choose the illustration that matches your application) for proper charger operation.

Incorrect wiring can result in reverse polarity. In the event this happens, the charger has been designed to not fail as a result, however it will cause the charger to "internally disconnect" and provide "no output" until the (reverse polarity) caused by putting the "Red" + lead on a - negative battery terminal). In the event of miswired battery(s), the charger will illuminate a red Battery Trouble Status LED for the specific battery requiring attention.

**Each charger cable** must be connected to 1 battery, as illustrated. Observe black wire to (-) and red wire to (+). Do this for each battery.

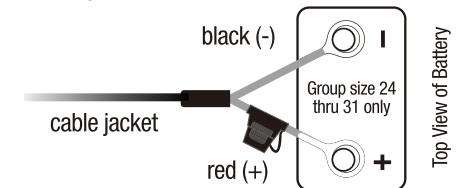

When connecting to an engine start battery only, connect the battery bank cable that is LABELED: "FOR ENGINE BATTERY USE THIS BANK CABLE ONLY".

If there are more charger outputs than batteries, then sets of leads can be doubled on the larger battery in your system. Typically these are connected to the more drained trolling motor battery

*Note: Battery Chargers are designed for any combination of group 24, 27, 29, 30 and 31 batteries. Each battery charger DC output cable must be connected to one (1) 12 volts DC battery (even if batteries are configured for 24 volts DC or 36 Volt DC trolling motor or system applications). Most specifically you do not have to remove series or parallel jumper cables to use your Charger.*

*Note: Your charger must be connected to the batteries to operate. It will not operate as an individual 2 volts power supply.*

## Installation

are located 4 inches from the end of each red (positive) cable. In addition, there are fuses in all but one of the black (negative) leads. These fuses protect the charger and output cables in the event of a short or reverse polarity. We recommend the use of wire ties or cable clamps to provide strain relief for the cables and to reduce the risk of damage to the cables or connections.

8. Connect the DC output cables as illustrated on pages 16-23. Make sure the (black) wires are connected to the negative side of the battery and the red wires are connected to the positive side of the battery

*Important Note: Your battery charger will not operate properly if it is not connected properly to each battery. Reminder, each DC jacketed bank cable must be properly connected to individual 12V batteries. Number of the DC jacketed bank cables equals the number of batteries that must be individually connected. For example, a 3 bank battery charger must be connected to 3 individual 12V batteries, as illustrated on pages 16-23. For charger setup, simply choose the illustration that has the same number of charger output bank cables as your battery charger in hand and wire exactly as shown (choose the illustration that matches your application) for proper charger operation.*

9. Make sure all DC connections are correct, tight, and free from corrosion.
10. Locate the AC power cord in an open-air area of your boat at least 21 inches from the charger, batteries, and fuel fill lines.
11. Connect a heavy duty UL approved extension cord to your charger first. After connecting the extension cord to the charger, proceed to plug the extension cord to a nearby 240VAC GFCI protected (Ground Fault Circuit Interrupt) outlet. Always remove the extension cord from the 240 VAC outlet first when charging is completed, followed by unplugging the charger. You are now connected and charging your batteries, and can monitor the progress by viewing the LED status indicators.

## Installation

Your battery charger is designed to be permanently mounted on-board, and can be mounted either vertically or horizontally.

Always mount your charger in a compartment area that can be properly ventilated during use.

Do NOT mix battery types on-board. All batteries should be of the same age and in good operating condition.

Do NOT make any electrical connections to the charger or batteries until the steps below are completed:

### Easy Steps for Installation:

1. Select a mounting location that allows for free air ventilation with a minimum of 6 inches of clear unobstructed space around and in front of your Battery Charger. Open all battery and engine compartments and ventilate for at least 15 minutes before starting the installation of the charger. Ensure all battery cables can reach each of the batteries.  
*Note: For installations requiring an extension of the DC battery charger cables, please call or visit your retailer or dealer to purchase a 5 foot or 15 foot battery charger DC cable extenders.*
2. Do not install charger on carpeted, upholstered, vinyl, or varnished areas. Make sure to place the charger in an accessible area where all indicators are clearly visible. Install this unit on a hard surface.
3. Using the battery charger or the enclosed template, mark the position of each mounting hole. Ensure the mounting screws will not puncture or protrude into a live well, a fuel or oil tank or the bottom of the boat.
4. Using a 1/8" drill bit, drill pilot holes in the (4) marked locations as described in step Apply a silicon sealer in each of the mounting locations to waterproof the screw holes.
5. Position the charger over the mounting holes and secure with a power screwdriver by installing 4 stainless steel # 10 screws. **(mounting screws are not supplied)**

1/8" pilot hole with silicon sealer

### IMPORTANT NOTICE

Confirm the surface you will be mounting the charger to is adequate in strength and thickness to hold the battery charger in place with the mounting screws you have selected.

Maintain an obstruction free area of 6 inches around the Battery Charger.

6. Prepare each battery in advance by cleaning each terminal post with a wire brush until a shiny surface is obtained.
7. Run cables free from sharp objects and secure the cables with cable ties. Coil excess cable, do not cut or shorten the length of the cables, as in-line fuses

